

Horizontal Maize Degermer



DHZ-4



DHZ-3



DHZ-2/A



DHZ-1

DHZ

ZACCARIA

Horizontal Maize Degermer DHZ

The machinery line of HORIZONTAL DEGERMER ZACCARIA model DHZ, have been developed with the purpose to remove the skin and the germ of corn kernels, contemplating the large and small production capacities.

The Degermers work coupled with Cereal Continuous Conditioner, our SCCZ (*). The SCCZ has the principle to facilitate the degermination process through the properly add of the moisture on the grains inside its chamber. This makes the process easier.

TECHNICAL DATA

Models	Power/ Poles	Capacity inlet: (kg/h)	Air Flow Required (m ³ /min)	Air Pressure Required (mm/H ₂ O)	Approx. Weight: packaged (Kg)	Approx. Volume: packaged (m ³)
DHZ-1	45 kW / 60 hp 50 Hz - 1500 rpm 60 Hz - 1800 rpm	1800 to 2500	40	-150 until -200	900	5
DHZ-2/A	22,5 kW / 30 hp 50 Hz - 1500 rpm 60 Hz - 1800 rpm	600 to 900	20	-150 until -180	440	2,5
DHZ-3	75 kW / 100 hp 50 Hz - 1500 rpm 60 Hz - 1800 rpm	3500 to 5000	50	-150 until -200	1210	5
DHZ-4	90 kW / 125 hp 50 Hz - 1500 rpm 60 Hz - 1800 rpm	5000 to 7000	80	-150 until -200	1500	6



DHZ-1

Example of mounting the DHZ-1 with the Conditioner SCCZ-2

Measures in mm / inches

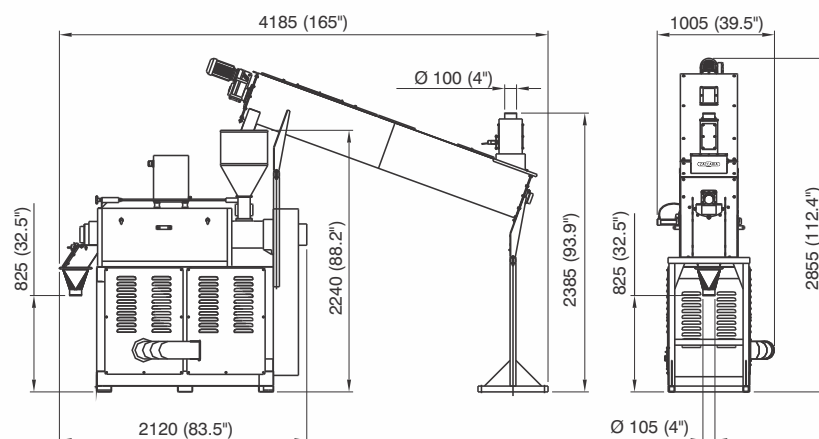

DHZ-2



Example of mounting the DHZ-2 with the Conditioner SCCZ-1

Measures in mm / inches

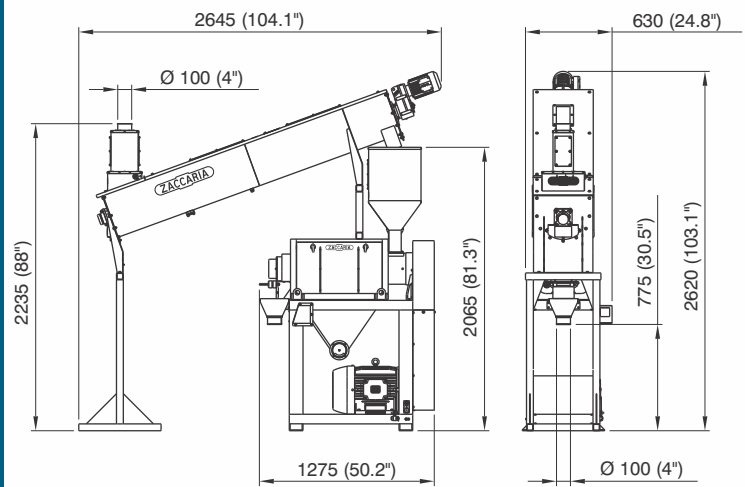

DHZ-3



Example of mounting the DHZ-3 with the Conditioner SCCZ-3

Measures in mm / inches

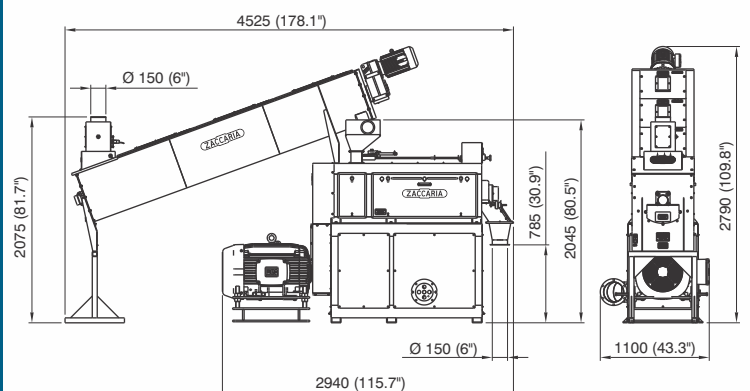

Horizontal Maize Degermer **DHZ**

DHZ-4



Example of mounting the DHZ-4 with the Conditioner SCCZ-4

Measures in mm/inche

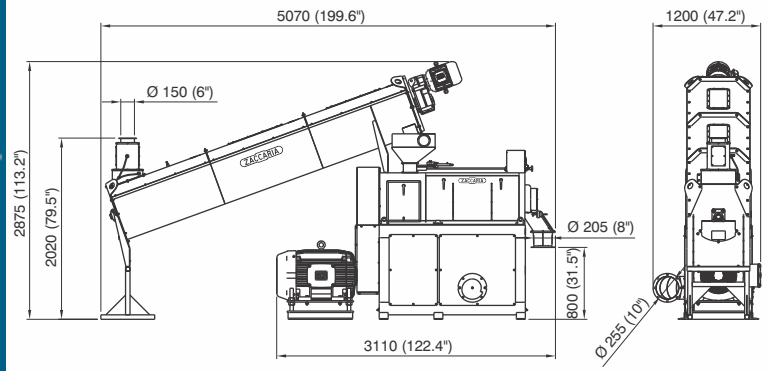

*For the optimization of the process of Degermination, we recommend to use the Cereal Continuous Conditioner, our SCCZ, which controls the continuous water flow, guaranteeing the humidity uniformly dispersed in the grains.

- Originally supplied without motor.



EXPERIENCE THAT MAKES THE DIFFERENCE

INDÚSTRIAS MACHINA ZACCARIA S/A
Rua Laranjal, 180
CEP: 13484-016 - Limeira - SP - Brasil
Fono: +55.19 3404-5745

www.zaccaria.com.br
comex@zaccaria.com.br

.....
Industrias Machina Zaccaria S/A reserves the right to change the information contained in this catalogue, including color and details, without previous notice.