

PLRZ-1M



Rural
Pre-Cleaner
PLRZ-1M

ZACCARIA

PLRZ-1M

Model:PLRZ-1M
.....**Power / poles:**

0,74 kW / VI

1 hp / VI
.....**Motor rotation (rpm):**

1200 (60 Hz)

1000 (50 Hz)
.....**Inlet capacity: paddy rice (kg/h):**2000
.....**Approximated weight: packaged (kg):**225
.....**Approximated volume: packaged (m³):**2,5
.....

Rural Pre-Cleaner PLRZ-1M

The Pre-Cleaner model PLRZ-1M executes cleaning, separating the impurities bigger and smaller than the cereals grains through the vibratory system, allied with the sieves configuration. The PLRZ-1M also does the cleaning by the airflow control. It separates the impurities heavier and lighter than the cereal grains.

The PLRZ-1M has a feed hopper, which one distributes uniformly the product to the aspiration channel to remove the lighter impurities. It has two sieves configuration, being responsible for the cleaning, removing the impurities bigger (first sieve) and smaller (second sieve) than the grains. The sieves frames are metallic, built in steel and the sieves have the system easy to fit in.

The PLRZ-1M is adaptable for several types of cereals, such as rice, maize, bean, soy, etc. The production capacity for other cereals different from rice must be checked.

FEATURES

- System for quick change of the sieves
- Drawer type system for easy removing of the frames, from behind
- Equipment very compact
- It works with several types of cereals (must be checked)
- The airflow system has two types of adjustments, offering the best performance at cleaning

OPTIONALS

- Inlet bucket elevator
- Outlet bucket elevator
- Sieves to do the cleaning in other cereals (under consult)

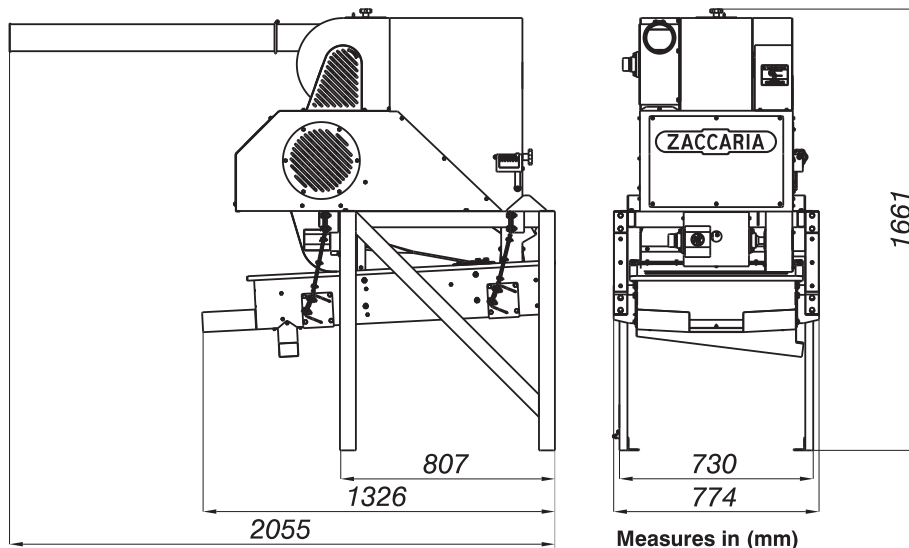

Note: The equipment does not have any part of wood in its building.

*Inlet Capacity for other type of cereals: under consult.

Equipment originally provided without motor. It follows with a set of sieves.

.....
Indústrias Machina Zaccaria S/A reserves the right to change the information contained in this catalog, including the color and details of the machine without previous notice.

ZACCARIA

OUR EXPERIENCE MAKES THE DIFFERENCE

INDÚSTRIAS MACHINA ZACCARIA S/A

Rua Laranjal, 180

CEP: 13484-016 - Limeira - SP - Brasil

Phone: (55.19) 3404 5745

www.zaccaria.com.br
comex@zaccaria.com.br

