

ZX-3

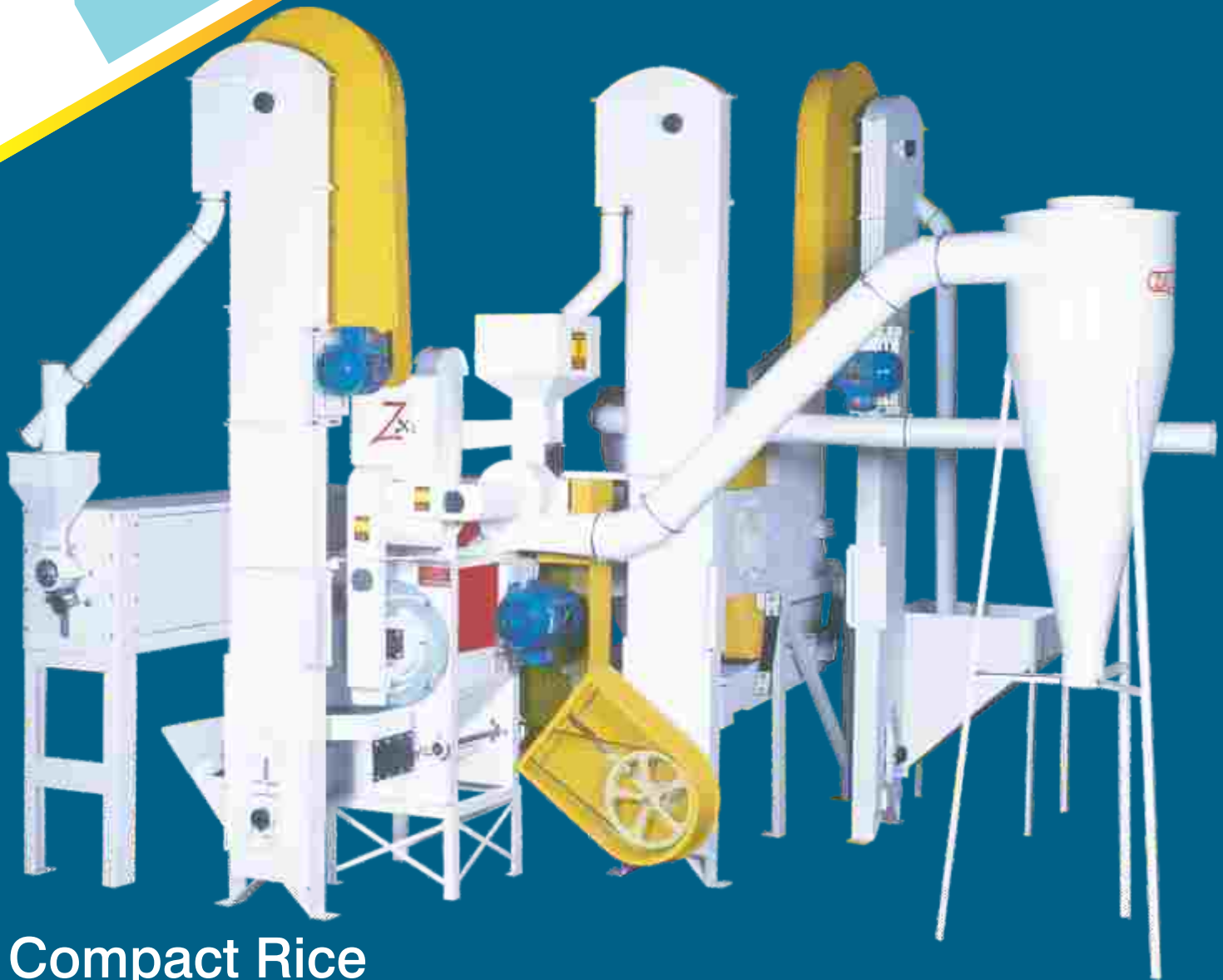

Compact Rice
Milling Machine
RURAL ZX-3
(with optionals)

ZACCARIA

ZX-3

Compact Rice Milling Machine RURAL ZX-3 (with optionals)

The Rural ZX-3 Compact Rice Milling Machine was developed to attend the requirements of small farms and small rice mills. The compact rice milling machine model ZX-3 is modern and has the compact conception which guarantee excellent yield and polishing in the most rice varieties with a small area and power consumption requirement. During the ZX-3 manufacture, only high quality materials and precision process are used, passing through rigorous programs of tests and quality.

Model:

RURAL ZX-3

Power / Poles:

- Three-phase electric motor (power system)
- ZX-3 and feed bucket elevator
 - 5 hp (3,7 kW)
 - 1500 rpm (50 Hz)
 - 1800 rpm (60 Hz)
- Length grader kit
 - 0,33 hp (0,25 kW)
 - 1500 rpm (50 Hz)
 - 1800 rpm (60 Hz)
- Length grader with bucket elevator
 - 0,75 hp (0,55 kW)
 - 1000 rpm (50 Hz)
 - 1200 rpm (60 Hz)
- Pré-Cleaner Rural PLRZ-1
 - 1,0 hp (0,74 kW)
 - 1000 rpm (50 Hz)
 - 1200 rpm (60 Hz)
- Pré-Cleaner Rural PLRZ-1 with bucket elevator
 - 0,75 hp (0,55 kW)
 - 1000 rpm (50 Hz)
 - 1200 rpm (60 Hz)
- Single-phase electric motor
 - 7,5 hp (5,5 kW)
 - 1500 rpm (50 Hz)
 - 1800 rpm (60 Hz)
- Diesel motor
 - 9,5 hp / 2400 rpm
- For other, under consult

Capacity (kg/h):

ZX-3 (paddy rice)
260 to 300

Approx. volume: Packaged (m³):

10

Approx. weight (without motor): Packaged (kg):

1300

Note: - Production in kg/h, based on tests long rice.
- For the best results, it is recommended that paddy moisture content should be within 12 to 13% (B. U.).
- Equipment originally supplied without motor.

Indústrias Machina Zaccaria S/A reserves the right to change the information contained in this catalog, including the color and details of the machine, without previous notice.

THE MACHINE CONSISTS OF

- Feed hopper
- Small cleaner to remove impurities
- Husk separation chamber
- Fan for husk suction
- Horizontal whitening with abrasive system easily exchangeable screens and brakes
- Simple and fast adjustment
- Metallic base for electric motor
- Oscillate screen set to separate small broken rice

OPTIONALS

- Diesel transmission
- Cyclone for husks
- Metallic base
- Bucket elevator including intake hopper
- Length grader for rice grading including bucket elevator
- Electric motor
- Pre-Cleaner RURAL PLRZ-1

Electric motor transmission (measures in mm/inches)

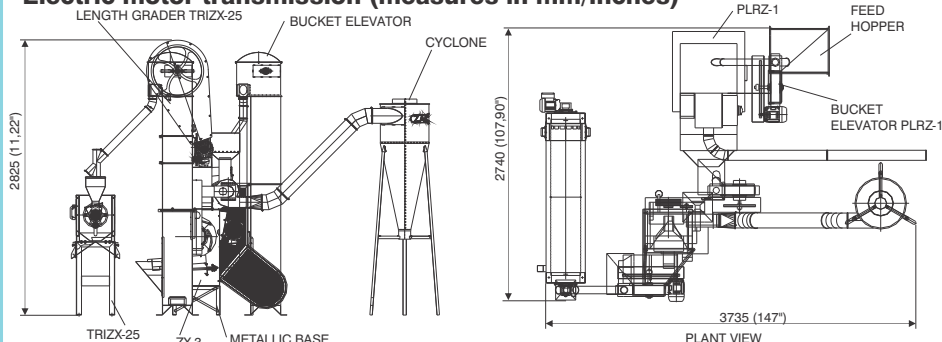

Diesel transmission single-phase (measures in mm/inches)

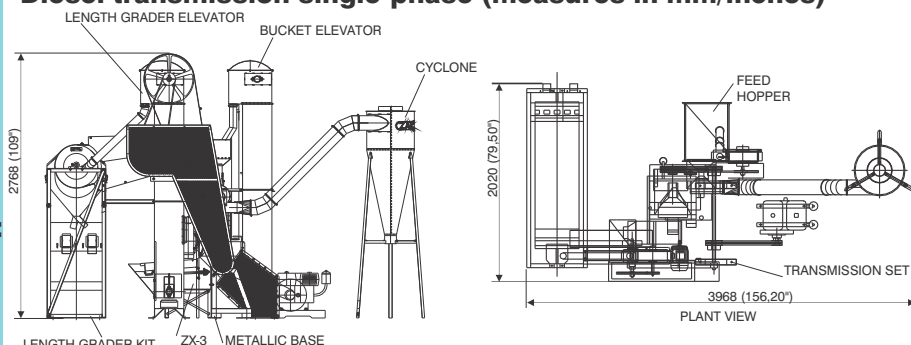

- Note: 1 - Transmission set for diesel motor 9,5 hp.
2 - Transmission for electric motor 7,5 hp (5,5 kW), single-phase 1500 rpm (50 Hz) or 1800 (60 Hz).
3 - Intermediate shaft rotation: 1010 rpm.
4 - Horizontal whitening rotation: 770 rpm.



EXPERIENCE THAT MAKES THE DIFFERENCE

INDÚSTRIAS MACHINA ZACCARIA S/A
Rua Laranjal, 180
CEP: 13484-016 - Limeira - SP - Brasil
Phone: +55.19 3404 5745

www.zaccaria.com.br
comex@zaccaria.com.br