

WPZ-2



Water
Polisher
WPZ-2

ZACCARIA

WPZ-2



Model:
WPZ-2

Required Power / Poles:

Main motor:
55 kW / IV
75 hp / IV

Conditioner:

0,25 kW / IV
0,33 hp / IV

Input capacity (kg/h):

6000 to 8400

Water polisher system:

Required water flow (l/h)
100

Required air flow (l/min)
150

Bran extraction:

Air pressure (mmH₂O)
-150 to -200

Required air volume (m³/min)
50

Approx. shipping volume (m³):

6

Approx. shipping weight (without motor) (kg):

1225

Water Polisher WPZ-2

In the constant searching to offer equipment, which provides the highest technology and capacity, Zaccaria presents the Water Polisher for rice model WPZ-2.

The WPZ-2 has in its features, the new generation of autonomous equipment, endowed with own intelligence, providing maximum productivity and quality, presenting the ideal solution for the milling industries, maximizing the results and bringing to the miller the lowest cost per tonne hour.

Once adjusted the initial configuration parameters and the equipment working on automatic mode, the electronic controller is in charge of keeping the constant production process, according to the previous defined parameters. This control enables total usage of the equipment, avoiding waste of power, obtaining the highest capacity, with a lower rate of broken grains, and offering the perfection of the finishing of the grains.

FEATURES

- Smart system for controlling inputting product, which uses its main motor power in the optimized way
- Control panel endowed with Touch-Screen
- Rice conditioning system incorporated to the equipment, providing more cleaned and polished grain, improving its visual aspect that maximizes the commercialization, reaching the most demanding quality standards, and also facilitating the next steps at milling processes
- Smart system at monitoring work, which manages and reports the behavior of the equipment
- Screens specially developed to ensure the most uniform polishing without damaging the surface of the grain
- Electronic panel with pump and water tank incorporated into the equipment
- Easy operation and control system, which alerts the periodic scheduled maintenance

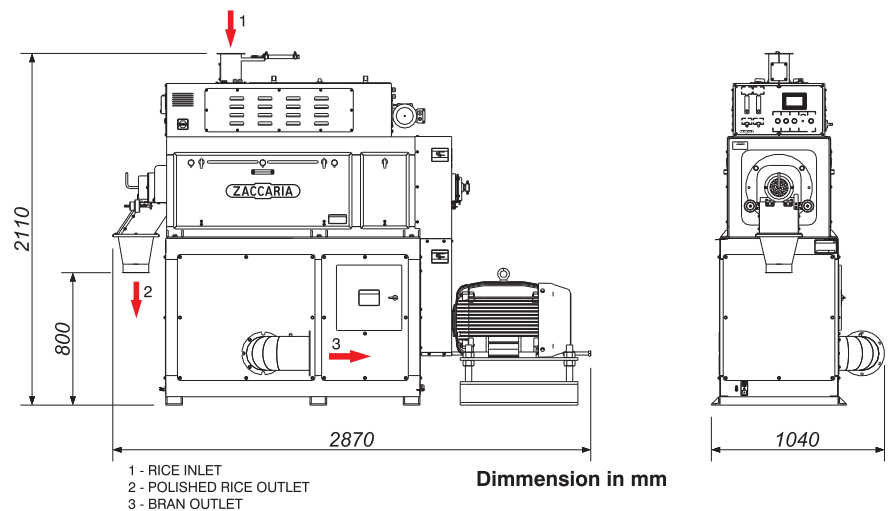

ZACCARIA

OUR EXPERIENCE MAKES THE DIFFERENCE

INDÚSTRIAS MACHINA ZACCARIA S/A
Rua Laranjal, 180
CEP: 13484-016 - Limeira - SP - Brasil
Phone: (55.19) 3404 5725
Fax: (55.19) 3404 5720

www.zaccaria.com.br
comex@zaccaria.com.br



- For maximum performance, paddy moisture content should be within 12 to 13% (B. U.).
- Machine originally supplied without motor.

Indústrias Machina Zaccaria S/A reserves the right to change the information stated in this catalog, including the color and details of the machine, without previous notice.