

HAZ



Sample
Homogenizer
HAZ

ZACCARIA

HAZ

Model:

HAZ

Sample Capacity:

- Until 4 kg for products with 600 kg/m³ density.
- Until 5,5 kg for products with 800 kg/m³ density.

Approximate Shipped Volume (m³):

0,6

Approximate Shipped Weight (kg):

27



.....
Indústrias Machina Zaccaria S/A reserves the right to change the specifications including the color of the machine and other details without previous notice.

Sample Homogenizer HAZ

To complement the Laboratory equipment Line, Zaccaria presents the SAMPLES HOMOGENIZER, model HAZ.

The HAZ is an easy-to-use and very useful equipment for your laboratory. The application of HAZ is fundamental for the companies that process cereals reach samples more homogeneous to perform their quality tests, achieving more accurate and reliable results in their tests.

The structure of the HAZ is made of SAE 1020 steel and its mixing barrel, where there is the contact with the product, it is made of stainless steel.

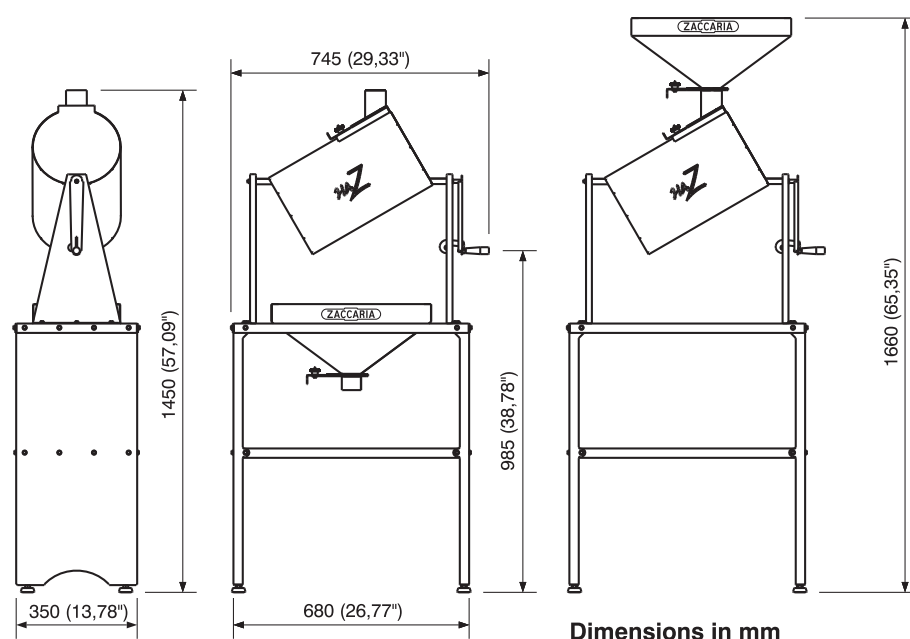

ZACCARIA

OUR EXPERIENCE MAKES THE DIFFERENCE

INDÚSTRIAS MACHINA ZACCARIA S/A

Rua Laranjal, 180
CEP: 13484-016 - Limeira - SP - Brasil
Phone: (55.19) 3404 5725
Fax: (55.19) 3404 5720

www.zaccaria.com.br
comex@zaccaria.com.br

