



EFZ-2



EFZ-2R

Suctioning
System
EFZ

ZACCARIA



Suctioning System EFZ

Zaccaria Suctioning System equipment were developed to transport small particles and to control the air pollution in the industries process.

As the EFZ system contain a centrifugal fan, a cyclone and a rotary valve, it efficiently performs the suction, decanting and dosing of the products.

The models EFZ-2 and EFZ-3 are used to aspirate bran generated from: rice whiteners, rice and bean polishers, maize degermers.

The model EFZ-2R, due to its sturdy structure, is used to aspirate and decant husks coming from the dehusking sector.

The set offer high efficiency with low maintenance.



*Note: Photo showing detail and illustrative drawings refer to model EFZ-2R.

TECHNICAL FEATURES

- Fan integrated to the cyclone head
- Low noise
- Low power consumption
- High efficiency

TECHNICAL DATA

Models	Fan Power/Poles	Rotary Valve Power/Poles	Air flow (m ³ /min)	Inlet pressure (mmH ₂ O)	Appoximated weight: packaged (Kg)	Appoximated volume: packaged (m ³)
EFZ-2 (60Hz)	7,5 kW / 10 hp / II poles	0,55 kW / 0,75 hp / IV poles	50	-240	310	4,27
EFZ-2 (50Hz)	5,5 kW / 7,5 hp / II poles	0,55 kW / 0,75 hp / IV poles	40	-150	310	4,27
EFZ-2R (60Hz)	5,5 kW / 7,5 hp / II poles	0,55 kW / 0,75 hp / IV poles	40	-150	417	4,27
EFZ-2R (50Hz)	5,5 kW / 7,5 hp / II poles	0,55 kW / 0,75 hp / IV poles	40	-150	417	4,27
EFZ-3 (60Hz)	3 kW / 4 hp / II poles	0,55 kW / 0,75 hp / IV poles	20	-150	255	3,96
EFZ-3 (50Hz)	3 kW / 4 hp / II poles	0,55 kW / 0,75 hp / IV poles	20	-150	255	3,96

Measures in mm / inches

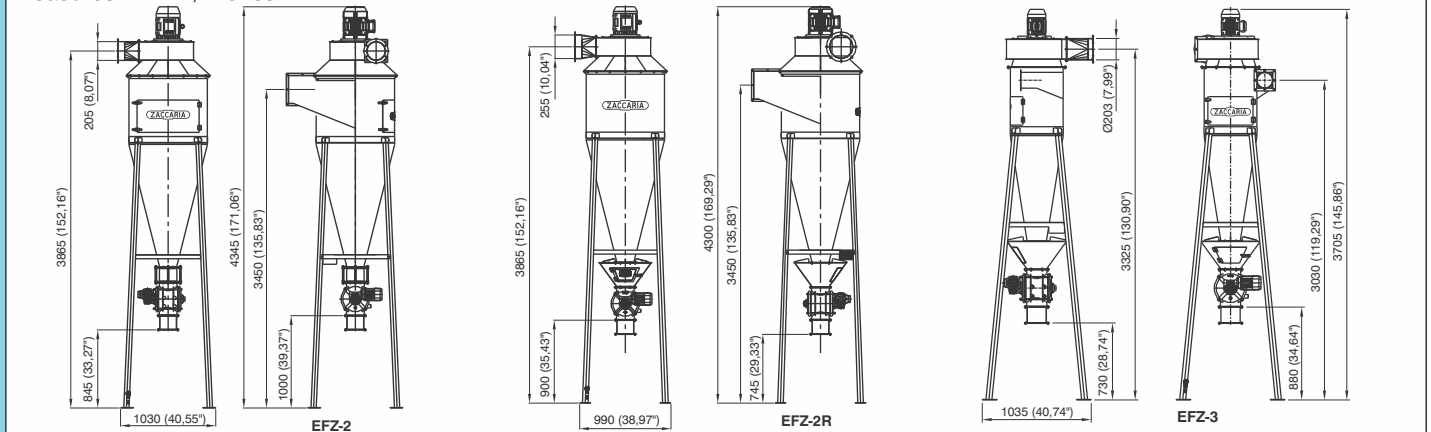

EXPERIENCE THAT MAKES THE DIFFERENCE

INDÚSTRIAS MACHINA ZACCARIA S/A
Rua Laranjal, 180
CEP: 13484-016 - Limeira - SP - Brasil
Phone: +55.19 3404 5745

www.zaccaria.com.br
comex@zaccaria.com.br

Equipped originally supplied with motors.

Indústrias Machina Zaccaria S/A reserves the right to change the information herein stated, including color and other details, without previous notice.